

The 12th Asian Association of Schools of Pharmacy Conference 2025  
Sponsorship Package Plan Application Guidelines

1. How to Apply

- ① Please visit the following URL or scan the QR code on the right.

URL : <https://smartconf.jp/content/aasp2025/sponsor>



- ② Fill in the required details on the sponsorship application form provided on the page.
- ③ After submitting the form, you will receive a confirmation email with a copy of your responses. The Secretariat will send you an invoice at a later date.

2. Application Deadline

May 2 (Fri.), 2025

\*Applications may close earlier than the deadline depending on the number of submissions.

3. Payment

The payment method will be by bank transfer. Further details will be provided by the Secretariat at a later date.

4. Contact

Secretariat of AASP 2025

c/o PCO Co., Ltd.

2-25, Sakurabashidori, Toyama city, Toyama, 930-0004, JAPAN

Tel : 076-461-7028

E-mail : [aasp2025@pcojapan.jp](mailto:aasp2025@pcojapan.jp)

## Package Plans

(incl. tax)

	Platinum	Gold	Silver	Bronze	Iron
	3,000,000 JPY	2,000,000 JPY	1,000,000 JPY	500,000 JPY	300,000 JPY
1) Company logo placement in the web program	•	•	•	•	•
2) Advertisement placement in the web program	•	•	•	•	•
3) Company logo placement in the printed program distributed at the venue	•	•	•	•	•
4) Company logo placement on signage at the venue	•	•	•	•	•
5) Company logo placement with hyperlinks on the website	•	•	•	•	•
6) Booth exhibition space	2	2	2	1	
7) Large company logo display in the main and sub-venues (Permanent during the conference)	•	•			
8) Enrollment in the "Kampo Aroma Course (e-learning)"**	30 ppl	20 ppl	10 ppl	5 ppl	3 ppl
9) Complimentary conference tickets including the banquet	5 ppl	4 ppl	3 ppl	2 ppl	1 ppl

## Package Plan: Details of Each Item

- 1) Logo Placement in the Web Program
  - The web program is an A4-sized PDF document, with all content in English.
  - Please send the logo data (JPG or PNG format) to the Secretariat via email.
  
- 2) Advertisement Placement in the Web Program
  - The web program is an A4-sized PDF document, with all content in English.
  - The location of your ad cannot be specified and will be determined by the Organizing Committee.
  - Please send the data as mentioned below to the Secretariat via email.
    - Size: Maximum 29.7 cm (height) × 21 cm (width)
    - File Format: Print-ready PDF with embedded fonts
    - Language: The content should primarily be all in English. If you wish to submit an advertisement in Japanese due to special circumstances, please consult with the Secretariat before applying.
  
- 3) Logo Placement in the Printed Program Distributed at the Venue
  - Please send the logo data (JPG or PNG format) to the Secretariat via email.
  
- 4) Logo Placement on Conference Venue Signage
  - Please send the logo data (JPG or PNG format) to the Secretariat via email.
  
- 5) Logo Placement on the Conference Website
  - The company logo will be displayed on the conference website.
  - Please send the logo data (JPG or PNG format) to the Secretariat via email.
  - The logo will include a hyperlink to your specified website. When submitting the logo data, please provide the website URL to be associated with the logo. \*English websites recommended
  
- 6) Booth Exhibition
  - Date: August 2 (Fri.) - August 3 (Sat.), 2025
  - Venue: Nihon Pharmaceutical University, Saitama Campus
  - Details including the setup dates/time will be provided later.

- Booth locations cannot be specified and will be determined by the Organizing Committee.
- Booth inclusions are as follows: \*Tentative
  - 2 back panels: W1,200mm×H1,800mm
  - 4 display tables:  
W1200mm×D450mm×H710mm
  - 4 chairs
  - Company name board

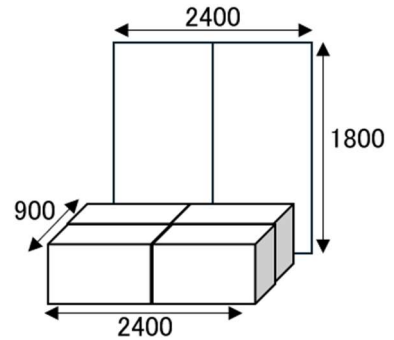

7) Large Company Logo Display in the Main and Sub-Conference Halls (Permanent during the conference)

- Details regarding the display method, size, and other specifics will be provided after the application is submitted.
- Please send the logo data (JPG or PNG format) to the Secretariat via email.

8) Enrollment in the "Kampo Aroma Course (e-learning)"

- Participants can take the Kampo Aroma Course offered by the Nippon Pharmaceutical University (Professional Practice Development Program recognized by the Minister of Education, Culture, Sports, Science and Technology)
- This is a top-ranked course in two categories: Humanities (Literature, Linguistics, Sociology, International Studies, Religion, Environment, etc.) and the Nursing, Medicine, Nutrition, Home Economics, and Lifestyle-related categories on "Manapass" (<https://manapass.jp/>) which is a learning website offered by the Ministry of Education, Culture, Sports, Science and Technology. This course offers the opportunity to learn and acquire knowledge related to herbal medicine, aromatherapy, acupuncture, health foods, cosmetics, supplements, hot springs, yoga, and more, from renowned experts. It also can be utilized to promote health management and improve the well-being of your employees.
- Details: <https://www.nichiyaku.ac.jp/kampo-aroma-course/>
- How to take the course: Instructions will be provided later.

9) Complimentary Conference Tickets with Banquet

- Includes participation in the conference programs and lunch during the conference (Friday, August 2, and Saturday, August 3), as well as the banquet on Saturday, August 3.
- The registration process on the day of the event will be provided later.