

The 12th Asian Association of Schools of Pharmacy Conference 2025
Sponsorship Application Guidelines by Category

1. How to Apply

- ① Please visit the following URL or scan the QR code on the right.

URL : <https://smartconf.jp/content/aasp2025/sponsor>



- ② Fill in the required details on the sponsorship application form provided on the page.
- ③ After submitting the form, you will receive a confirmation email with a copy of your responses. The Secretariat will send you an invoice later.

2. Application Deadline

May 2 (Fri.), 2025

*Applications may close earlier than the deadline depending on the number of submissions.

3. Payment

The payment method will be by bank transfer. Further details will be provided by the Secretariat at a later date.

4. Contact

Secretariat of AASP 2025

c/o PCO Co., Ltd.

2-25, Sakurabashidori, Toyama city, Toyama, 930-0004, JAPAN

Tel : 076-461-7028

E-mail : aasp2025@pcojapan.jp

Sponsorship Items

A) Advertisement Placement in the Web Program: 100,000 JPY (Incl. Tax)

- The web program is an A4-sized PDF document, with all content in English.
- The location of your ad cannot be specified and will be determined by the Organizing Committee.
- Please send the data as mentioned below to the Secretariat via email.
 - Size: Maximum 29.7 cm (height) × 21 cm (width)
 - File Format: Print-ready PDF with embedded fonts
 - Language: The content should primarily be all in English. If you wish to submit an advertisement in Japanese due to special circumstances, please consult with the Secretariat before applying.

B) Logo Placement on the Conference Website: 50,000 JPY (Incl. Tax)

- The company logo will be displayed on the conference website.
- Please send the logo data (JPG or PNG format) to the Secretariat via email.
- The logo will include a hyperlink to your specified website. When submitting the logo data, please provide the website URL to be associated with the logo. *English websites recommended

C) Booth Exhibition: 1 space 200,000 JPY, 2 space 400,000 JPY (Incl. Tax)

- Date: August 2 (Fri.) - August 3 (Sat.), 2025
- Venue: Nihon Pharmaceutical University, Saitama Campus
- Details including the setup dates/time will be provided later.
- Booth locations cannot be specified and will be determined by the Organizing Committee.
- Booth inclusions are as follows: *Tentative
 - 2 back panels: W1,200mm×H1,800mm
 - 4 display tables:
W1200mm×D450mm×H710mm
 - 4 chairs
 - Company name board

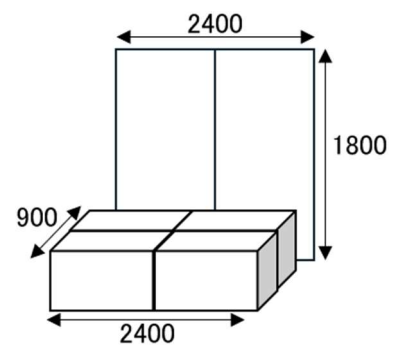

D) Conference Bags: Provision of Items (In-Kind Contribution): 400 units

- They will be distributed to the participants at the venue.
- Details about the bags and the shipping address will be provided by the Secretariat.
- Please cover all costs related to production, including shipping fees to the venue.

E) Name Straps: Provision of Items (In-Kind Contribution): 400 units

- These will be worn by participants and staff during the conference.
- Details about the straps and the shipping address will be provided by the Secretariat.
- Please cover all costs related to production, including shipping fees to the venue.